

SPECIFICATION
OF
KATO CITY RANGE CRANE

MODEL CR-250RV

KATO WORKS CO., LTD.

Tokyo, Japan

SPECIFICATION OF CR-250RV

1. Crane Specification

Maximum lifting capacity	:	25 ton × 2.8 m
Boom length	:	6.7 m – 29.0 m (6 section)
Jib length	:	5.3 m – 8.2 m (2 section, offset 7°– 60°)
Searcher hook (option)	:	1.0 m (High position and Low position)
Boom derricking angle	:	-9°– 84°
*Boom derricking time	:	38 s / -9°– 84°
*Boom extending speed	:	6.7 m – 29.0 m / 69 s
*Hoisting line speed (winch up)		
Main winch	:	115 m/min (at 4th layer)
Auxiliary winch	:	115 m/min (at 4th layer)
*Hoisting hook speed (winch up)		
Main winch	:	16.4 m/min (at 4th layer)
(parts of line:7)		
Auxiliary winch	:	115.0 m/min (at 4th layer)
(parts of line:1)		
*Slewing speed	:	2.5 min ⁻¹
*Speed / Time	:	Subject to no load
Wire rope for hoisting		
Main winch;		
Diameter	:	16 mm
Length	:	165 m
Auxiliary winch;		
Diameter	:	16 mm
Length	:	85 m
Hydraulic system		
Oil pump	:	4 pumps, plunger and gear type
Hoisting motor	:	Axial plunger type
Slewing motor	:	Axial plunger type
Cylinder	:	Double acting type
Control valve	:	Double acting with integral check and relief valves
Oil reservoir capacity	:	370 L

Winch system	
Main winch	: Driven by axial plunger type
Auxiliary winch	: hoisting motor through planetary gear reduction. Controlled independently by 2-speed (high / low) selection type respective operating lever. Equipped with automatic brake.
Safety devices	: ACS (Automatic Crane System with Voice alarm) ACS outside indicator (LED) Slewing automatic stop system Boom raise / lower dampening function Boom extension / retraction dampening function Working range limit mode Outrigger status detector Outrigger lock pins Electronical horizontal detector Boom derricking / telescoping holding valve Jib derricking / telescoping holding valve Overhoist prevention device Winch holding valve Automatic winch brake Winch drum roller Winch drum turning indication device Winch over unwinding device Hydraulic safety valves Hydraulic oil temperature warning device Hydraulic oil return filter warning device Slewing lock Slewing warning lamp Seat switch Left front, Left rear and Right rear view camera (With human detection assist function)
Operator's cab	: All steel welded construction, 1 person Rubber mounted Adjustable steering wheel Adjustable seat with suspension Air conditioner Power window (external closing switch) Front windscreen wiper & washer (2 speed wiper) Roof window wiper & washer (2 speed wiper) 12-inch touch monitor Bluetooth radio * Interior lamp (LED) Step lamp (LED) Accessory socket (24V) USB & AUX port (USB output 5V-2A) * Floor mat Entry key system K·COR (KATO Crane Operation Recorder)
Standard equipment	: Working light (LED) on boom, table and cab Winch view camera Hook for 25 ton Hook for 4 ton

*Note: Destination areas where bluetooth radio can be used are limited by the Radio Act of each country, so please contact us if necessary.

Optional equipment : PA system
Door visor
Tea table
Air heater
Searcher hook
Anemometer
Hands free microphone *
Camera cleaner for winch camera and boom
front view camera

*Note: Destination areas where hands free microphone can be used are limited by the Radio Act of each country, so please contact us if necessary.

2. Carrier Specification

Drive system		: 4 × 2 , 4 × 4
Maximum traveling speed		: 62 km/h
Grade ability (tan θ)		: 60 % (computed at G.V.W. = 23795 kg)
Minimum turning radius (center of extreme outer tire)		: 5.0 m (4 wheel steer) 8.3 m (2 wheel steer)
Engine		
	Maker	: Cummins
	Model	: B6.7 (EU Stage 5)
	Type	: 4 cycle, 6 cylinders, water cooled, direct injection turbo-charged diesel engine with intercooling
	Piston displacement	: 6.690 L
	Max. power	: 209 kW at 2200 min ⁻¹
	Max. torque	: 1152 N·m at 1500 min ⁻¹
Torque converter		: Engine mounted 3 elements 1 stage (with lock up clutch)
Transmission		: Remote mounted full automatic 4 forward & 1 reverse speed (with High-Low selector)
Axles;	Front & Rear	: Planetary, drive/steer type, Reverse“ELLIOT” type
Suspension;	Front & Rear	: Hydro-pneumatic suspension Hydraulic locking device with suspension cylinder
Steering		: Full hydraulic power steering Front, coordinated, crab, rear, completely independent front and rear steering (with automatic rear wheel steering lock system)
Brake system;	Service brake	: Air-over hydraulic disk brake on 4 wheels (front and rear independent circuit) ABS (Anti-lock Brake System)
	Parking brake	: Spring applied, electrically air released parking brake mounted on front axle
	Auxiliary brake	: Exhaust brake Service brake lock
Electric system		: 24 V
Alternator		: 24 V – 70 A
Batteries		: (12 V – 120 Ah) × 2
Fuel tank capacity		: 300 L
Tire size	Front & Rear	: 385 / 95 R25 170E ROAD

Safety devices	: Emergency steering device Rear wheel steering lock system (automatic) Brake fluid leak warning device Service brake lock Suspension lock Engine overspeed alarm Electrically retractable side view mirrors Surround view system Clearance sonar system Radiator coolant level warning device Air filter service warning device Low air warning device Boom front view camera Boom guard
Standard equipment	: Hydraulic oil cooler LED head lamp
Optional equipments	: Wheel stopper Way side lamp Side marker lamp Electrically adjustable side view mirrors with defroster Aluminum outrigger plate and storage Resin outrigger plate and storage Camera cleaner for surround view system Tire pressure monitoring system *

*Note: Destination areas where tire pressure monitoring system can be used are limited by the Radio Act of each country, so please contact us if necessary.

3.General dimensions

Overall length	: 9195 mm
Overall width	: 2395 mm
Overall height	: 3495 mm
Wheel base	: 3540 mm
Treads;	Front : 1970 mm
	Rear : 1970 mm
Outriggers	Type Hydraulic H-beam type (with float and vertical cylinder in single unit)
	Extension width : 6000mm (Fully extended)
	: 5200mm (Intermediately extended)
	: 4400mm (Intermediately extended)
	: 3400mm (Intermediately extended)
	: 2085mm (Completely retracted)
Gross vehicle weight	: 23795 kg (without Optional equipments)
Front axle	: 11895 kg (without Optional equipments)
Rear axle	: 11900 kg (without Optional equipments)

LIFTING CAPACITIES (1)

Based on ISO 4305

Not exceed 75 % of static tipping loads

Working radius(m)	Outriggers fully extended (6.0m) 360° full range					
	6.7m Boom	11.25m Boom	15.74m Boom	20.2m Boom	24.6m Boom	29.0m Boom
2.8	25.00*	13.00	12.00	9.00	8.00	7.00
3.0	22.00	13.00	12.00	9.00	8.00	7.00
3.5	20.00	13.00	12.00	9.00	8.00	7.00
4.0	17.00	13.00	12.00	9.00	8.00	7.00
4.5	15.00	13.00	12.00	9.00	8.00	7.00
5.0		13.00	12.00	9.00	8.00	7.00
5.5		13.00	12.00	9.00	8.00	7.00
6.0		12.00	11.50	9.00	8.00	7.00
6.5		11.30	10.65	9.00	8.00	7.00
7.0		10.40	9.90	9.00	8.00	7.00
8.0		7.90	7.90	8.30	8.00	6.80
9.0		6.20	6.20	6.60	6.90	6.20
10.0			5.00	5.35	5.65	5.70
11.0			4.05	4.40	4.70	4.90
12.0			3.35	3.70	3.95	4.15
13.0			2.75	3.10	3.40	3.55
14.0				2.65	2.90	3.05
15.0				2.25	2.50	2.65
16.0				1.95	2.15	2.35
17.0				1.65	1.90	2.05
18.0				1.40	1.65	1.80
19.0					1.40	1.55
20.0					1.25	1.40
21.0					1.05	1.20
22.0					0.90	1.05
23.0						0.90
24.0						0.80
25.0						0.65
26.0						0.55
27.0						0.45
Critical boom angle(°)	-	-	-	-	-	-
Parts of line	7*,6	6	4	4	4	4
Standard hook	For 25ton					
Hook mass (kg)	220					

(Unit : Metric ton)

LIFTING CAPACITIES (2)

Based on ISO 4305

Not exceed 75 % of static tipping loads

Outriggers intermediately extended (5.2m) over side						
Working radius(m)	6.7m Boom	11.25m Boom	15.74m Boom	20.2m Boom	24.6m Boom	29.0m Boom
2.8	25.00*	13.00	12.00	9.00	8.00	7.00
3.0	22.00	13.00	12.00	9.00	8.00	7.00
3.5	20.00	13.00	12.00	9.00	8.00	7.00
4.0	17.00	13.00	12.00	9.00	8.00	7.00
4.5	15.00	13.00	12.00	9.00	8.00	7.00
5.0		13.00	12.00	9.00	8.00	7.00
5.5		13.00	12.00	9.00	8.00	7.00
6.0		10.90	10.80	9.00	8.00	7.00
6.5		9.20	9.15	9.00	8.00	7.00
7.0		7.95	7.85	8.20	8.00	7.00
8.0		6.05	6.00	6.35	6.65	6.80
9.0		4.75	4.75	5.05	5.35	5.55
10.0			3.80	4.15	4.40	4.60
11.0			3.05	3.40	3.65	3.85
12.0			2.50	2.85	3.10	3.25
13.0			2.05	2.40	2.60	2.80
14.0				2.00	2.25	2.40
15.0				1.70	1.90	2.05
16.0				1.40	1.65	1.80
17.0				1.20	1.40	1.55
18.0				1.00	1.20	1.35
19.0					1.00	1.15
20.0					0.85	1.00
21.0					0.70	0.85
22.0					0.60	0.75
23.0						0.60
24.0						0.50
Critical boom angle(°)	-	-	-	-	-	28
Parts of line	7*,6	6	4	4	4	4
Standard hook	For 25ton					
Hook mass (kg)	220					

(Unit : Metric ton)

LIFTING CAPACITIES (3)

Based on ISO 4305

Not exceed 75 % of static tipping loads

Outriggers intermediately extended (4.4m) over side						
Working radius(m)	6.7m Boom	11.25m Boom	15.74m Boom	20.2m Boom	24.6m Boom	29.0m Boom
2.8	22.00	13.00	12.00	9.00	8.00	7.00
3.0	22.00	13.00	12.00	9.00	8.00	7.00
3.5	20.00	13.00	12.00	9.00	8.00	7.00
4.0	17.00	13.00	12.00	9.00	8.00	7.00
4.5	14.30	13.00	12.00	9.00	8.00	7.00
5.0		11.40	11.35	9.00	8.00	7.00
5.5		9.35	9.35	9.00	8.00	7.00
6.0		7.85	7.85	8.15	8.00	7.00
6.5		6.70	6.70	7.00	7.30	7.00
7.0		5.80	5.75	6.10	6.40	6.60
8.0		4.40	4.40	4.70	5.00	5.20
9.0		3.45	3.45	3.75	4.00	4.20
10.0			2.70	3.05	3.25	3.45
11.0			2.15	2.45	2.70	2.90
12.0			1.70	2.00	2.25	2.40
13.0			1.35	1.65	1.90	2.05
14.0				1.35	1.55	1.75
15.0				1.10	1.30	1.45
16.0				0.90	1.10	1.25
17.0				0.70	0.90	1.05
18.0				0.50	0.75	0.85
19.0					0.60	0.70
20.0					0.45	0.60
21.0						0.45
Critical boom angle(°)	-	-	-	-	28	40
Parts of line	6	6	4	4	4	4
Standard hook	For 25ton					
Hook mass (kg)	220					

(Unit : Metric ton)

LIFTING CAPACITIES (4)

Based on ISO 4305

Not exceed 75 % of static tipping loads

Outriggers intermediately extended (3.4m) over side						
Working radius(m)	6.7m Boom	11.25m Boom	15.74m Boom	20.2m Boom	24.6m Boom	29.0m Boom
2.8	20.00	13.00	12.00	9.00	8.00	7.00
3.0	20.00	13.00	12.00	9.00	8.00	7.00
3.5	14.65	13.00	12.00	9.00	8.00	7.00
4.0	11.10	11.10	11.00	9.00	8.00	7.00
4.5	8.75	8.75	8.70	8.80	8.00	7.00
5.0		7.15	7.10	7.35	7.35	7.00
5.5		5.90	5.90	6.15	6.40	6.30
6.0		5.00	4.95	5.25	5.55	5.55
6.5		4.25	4.20	4.50	4.80	4.95
7.0		3.65	3.60	3.90	4.20	4.40
8.0		2.70	2.70	3.00	3.25	3.45
9.0		2.05	2.05	2.35	2.55	2.75
10.0			1.50	1.85	2.05	2.20
11.0			1.10	1.45	1.65	1.80
12.0			0.80	1.10	1.30	1.45
13.0			0.50	0.85	1.05	1.20
14.0				0.60	0.80	0.95
15.0					0.65	0.75
Critical boom angle(°)	-	-	-	39	48	56
Parts of line	6	6	4	4	4	4
Standard hook	For 25ton					
Hook mass (kg)	220					

(Unit : Metric ton)

LIFTING CAPACITIES (5)

Based on ISO 4305

Not exceed 75 % of static tipping loads

Outriggers completely retracted (2.085m) over side						
Working radius(m)	6.7m Boom	11.25m Boom	15.74m Boom	20.2m Boom	24.6m Boom	29.0m Boom
2.8	9.70	9.70	8.85	8.30	7.85	6.25
3.0	8.55	8.55	8.00	7.60	7.25	5.80
3.5	6.40	6.40	6.35	6.15	6.00	4.90
4.0	5.00	5.00	4.95	5.05	5.00	4.20
4.5	3.95	3.95	3.95	4.20	4.25	3.60
5.0		3.20	3.20	3.50	3.60	3.15
5.5		2.60	2.60	2.90	3.10	2.70
6.0		2.15	2.10	2.45	2.65	2.35
6.5		1.75	1.75	2.05	2.25	2.05
7.0		1.40	1.40	1.70	1.95	1.80
8.0		0.90		1.20	1.40	1.30
9.0		0.55				
Critical boom angle(°)	-	-	57	62	68	72
Parts of line	6	4	4	4	4	4
Standard hook	For 25ton					
Hook mass (kg)	220					

(Unit : Metric ton)

LIFTING CAPACITIES (6)

Based on ISO 4305

Not exceed 75 % static tipping loads

20.2 m Boom + 5.3 m Jib								
Outriggers fully extended (6.0m)				360° full range				
Boom angle (°)	Offset 7°		Offset 25°		Offset 45°		Offset 60°	
	Working radius (m)	Load (ton)	Working radius (m)	Load (ton)	Working radius (m)	Load (ton)	Working radius (m)	Load (ton)
84	2.7	3.00	4.3	3.00	5.7	1.90	6.3	1.25
82	3.6	3.00	5.2	3.00	6.5	1.90	7.1	1.25
79	4.9	3.00	6.5	3.00	7.7	1.85	8.2	1.25
76	6.2	3.00	7.7	3.00	8.9	1.75	9.3	1.25
73	7.5	3.00	9.0	3.00	10.0	1.70	10.4	1.20
70	8.8	3.00	10.2	2.90	11.1	1.65	11.4	1.20
67	10.0	3.00	11.3	2.75	12.2	1.60	12.5	1.20
64	11.2	3.00	12.5	2.55	13.2	1.55	13.4	1.20
61	12.4	3.00	13.6	2.45	14.2	1.50	14.3	1.15
58	13.6	2.95	14.6	2.35	15.2	1.50		
55	14.6	2.60	15.6	2.25	16.1	1.50		
53	15.3	2.35	16.2	2.15	16.6	1.45		
50	16.2	2.00	17.1	1.90	17.7	1.45		
46	17.5	1.65	18.2	1.60	18.4	1.40		
45	17.7	1.60	18.4	1.50				
40	19.1	1.30	19.7	1.25				
37	19.8	1.15	20.3	1.10				
35	20.3	1.05	20.7	1.05				
30	21.3	0.88	21.6	0.88				
26	22.0	0.74	22.2	0.74				
25	22.1	0.72						
20	22.8	0.61						
15	23.3	0.53						
10	23.6	0.48						
Critical boom angle(°)	9		25		45		60	
Parts of line	1							
Standard hook	For 4ton							
Hook mass (kg)	60							

(Unit : Metric ton)

LIFTING CAPACITIES (7)

Based on ISO 4305

Not exceed 75 % static tipping loads

20.2 m Boom + 5.3 m Jib								
Outriggers intermediately extended (5.2m)					over side			
Boom angle (°)	Offset 7°		Offset 25°		Offset 45°		Offset 60°	
	Working radius (m)	Load (ton)	Working radius (m)	Load (ton)	Working radius (m)	Load (ton)	Working radius (m)	Load (ton)
84	2.7	3.00	4.3	3.00	5.7	1.90	6.3	1.25
82	3.6	3.00	5.2	3.00	6.5	1.90	7.1	1.25
79	4.9	3.00	6.5	3.00	7.7	1.85	8.2	1.25
76	6.2	3.00	7.7	3.00	8.9	1.75	9.3	1.25
73	7.5	3.00	9.0	3.00	10.0	1.70	10.4	1.20
70	8.8	3.00	10.2	2.90	11.1	1.65	11.4	1.20
67	10.0	3.00	11.3	2.75	12.2	1.60	12.5	1.20
64	11.2	3.00	12.5	2.55	13.2	1.55	13.4	1.20
61	12.4	2.85	13.6	2.45	14.2	1.50	14.3	1.15
58	13.6	2.35	14.6	2.15	15.2	1.50		
55	14.6	1.95	15.6	1.80	16.1	1.50		
53	15.3	1.75	16.2	1.65	16.6	1.45		
50	16.2	1.50	17.1	1.40	17.4	1.40		
46	17.3	1.25	18.2	1.15	18.4	1.15		
45	17.6	1.15	18.4	1.10				
40	18.9	0.93	19.6	0.88				
37	19.7	0.79	20.3	0.77				
35	20.2	0.71	20.7	0.70				
30	21.2	0.54	21.6	0.54				
26	21.9	0.41	22.2	0.41				
25	22.1	0.39						
20	22.8	0.29						
15	23.3	0.22						
Critical boom angle(°)	14		25		45		60	
Parts of line	1							
Standard hook	For 4ton							
Hook mass (kg)	60							

(Unit : Metric ton)

LIFTING CAPACITIES (8)

Based on ISO 4305

Not exceed 75 % static tipping loads

20.2 m Boom + 5.3 m Jib								
Outriggers intermediately extended (4.4m)					over side			
Boom angle (°)	Offset 7°		Offset 25°		Offset 45°		Offset 60°	
	Working radius (m)	Load (ton)	Working radius (m)	Load (ton)	Working radius (m)	Load (ton)	Working radius (m)	Load (ton)
84	2.7	3.00	4.3	3.00	5.7	1.90	6.3	1.25
82	3.6	3.00	5.2	3.00	6.5	1.90	7.1	1.25
79	4.9	3.00	6.5	3.00	7.7	1.85	8.2	1.25
76	6.2	3.00	7.7	3.00	8.9	1.75	9.3	1.25
73	7.5	3.00	9.0	3.00	10.0	1.70	10.4	1.20
70	8.8	3.00	10.2	2.90	11.1	1.65	11.4	1.20
67	10.0	3.00	11.3	2.70	12.2	1.60	12.5	1.20
64	11.2	2.55	12.5	2.20	13.2	1.55	13.4	1.20
61	12.4	2.05	13.5	1.80	14.2	1.50	14.3	1.15
58	13.4	1.65	14.5	1.50	15.2	1.40		
55	14.5	1.35	15.5	1.25	16.0	1.20		
53	15.2	1.20	16.1	1.10	16.6	1.05		
50	16.1	0.98	17.0	0.92	17.4	0.90		
46	17.3	0.75	18.1	0.71	18.4	0.70		
45	17.6	0.69	18.3	0.66				
40	19.0	0.47	19.6	0.46				
37	19.7	0.35	20.3	0.35				
35	20.2	0.28	20.7	0.28				
Critical boom angle(°)	34		34		45		60	
Parts of line	1							
Standard hook	For 4ton							
Hook mass (kg)	60							

(Unit : Metric ton)

LIFTING CAPACITIES (9)

Based on ISO 4305

Not exceed 75 % static tipping loads

20.2 m Boom + 5.3 m Jib								
Outriggers intermediately extended (3.4m)					over side			
Boom angle (°)	Offset 7°		Offset 25°		Offset 45°		Offset 60°	
	Working radius (m)	Load (ton)	Working radius (m)	Load (ton)	Working radius (m)	Load (ton)	Working radius (m)	Load (ton)
84	2.7	3.00	4.3	3.00	5.7	1.90	6.3	1.25
82	3.6	3.00	5.2	3.00	6.5	1.90	7.1	1.25
79	4.9	3.00	6.5	3.00	7.7	1.85	8.2	1.25
76	6.2	3.00	7.7	3.00	8.9	1.75	9.3	1.25
73	7.5	3.00	9.0	2.95	10.0	1.70	10.4	1.20
70	8.8	2.75	10.2	2.25	11.1	1.65	11.4	1.20
67	10.0	2.10	11.3	1.75	12.2	1.60	12.5	1.20
64	11.1	1.60	12.4	1.40	13.2	1.30	13.4	1.20
61	12.2	1.20	13.4	1.05	14.1	1.00	14.3	1.00
58	13.3	0.94	14.4	0.84	15.1	0.79		
55	14.4	0.71	15.4	0.64	16.0	0.60		
Critical boom angle(°)	54		54		54		60	
Parts of line	1							
Standard hook	For 4ton							
Hook mass (kg)	60							

(Unit : Metric ton)

LIFTING CAPACITIES (10)

Based on ISO 4305

Not exceed 75 % static tipping loads

29.0 m Boom + 5.3 m Jib								
Outriggers fully extended (6.0m)				360° full range				
Boom angle (°)	Offset 7°		Offset 25°		Offset 45°		Offset 60°	
	Working radius (m)	Load (ton)	Working radius (m)	Load (ton)	Working radius (m)	Load (ton)	Working radius (m)	Load (ton)
84	4.2	3.00	6.1	3.00	7.3	1.90	7.7	1.25
82	5.5	3.00	7.4	2.95	8.4	1.90	8.8	1.25
79	7.5	3.00	9.2	2.65	10.1	1.80	10.5	1.25
76	9.5	3.00	11.0	2.40	11.8	1.70	12.1	1.20
73	11.3	2.90	12.6	2.15	13.4	1.65	13.6	1.20
70	13.0	2.55	14.2	1.95	15.0	1.60	15.1	1.20
67	14.7	2.25	15.8	1.80	16.5	1.55	16.6	1.20
64	16.3	2.05	17.3	1.70	18.0	1.50	17.9	1.15
61	17.8	1.75	18.8	1.55	19.3	1.40	19.3	1.15
58	19.2	1.45	20.1	1.35	20.6	1.30		
55	20.5	1.20	21.4	1.10	21.8	1.10		
53	21.3	1.05	22.2	0.99	22.6	0.99		
50	22.6	0.87	23.4	0.82	23.7	0.82		
46	24.1	0.64	24.9	0.62	25.0	0.62		
45	24.5	0.59	25.2	0.58				
40	26.3	0.37	26.8	0.37				
37	27.3	0.26	27.7	0.26				
35	27.9	0.20						
Critical boom angle(°)	34		36		45		60	
Parts of line	1							
Standard hook	For 4ton							
Hook mass (kg)	60							

(Unit : Metric ton)

LIFTING CAPACITIES (11)

Based on ISO 4305

Not exceed 75 % static tipping loads

29.0 m Boom + 5.3 m Jib								
Outriggers intermediately extended (5.2m)					over side			
Boom angle (°)	Offset 7°		Offset 25°		Offset 45°		Offset 60°	
	Working radius (m)	Load (ton)	Working radius (m)	Load (ton)	Working radius (m)	Load (ton)	Working radius (m)	Load (ton)
84	4.2	3.00	6.1	3.00	7.3	1.90	7.7	1.25
82	5.5	3.00	7.4	2.95	8.4	1.90	8.8	1.25
79	7.5	3.00	9.2	2.65	10.1	1.80	10.5	1.25
76	9.5	3.00	11.0	2.40	11.8	1.70	12.1	1.20
73	11.3	2.90	12.6	2.15	13.4	1.65	13.6	1.20
70	13.0	2.55	14.2	1.95	15.0	1.60	15.1	1.20
67	14.7	2.10	15.8	1.80	16.5	1.55	16.6	1.20
64	16.1	1.70	17.3	1.55	18.0	1.45	17.9	1.15
61	17.6	1.35	18.7	1.25	19.3	1.20	19.3	1.15
58	19.1	1.05	20.0	1.00	20.6	0.98		
55	20.4	0.85	21.2	0.83	21.7	0.80		
53	21.2	0.74	22.0	0.71	22.4	0.70		
50	22.5	0.56	23.2	0.55	23.5	0.55		
46	24.0	0.36	24.7	0.35	24.9	0.35		
45	24.3	0.32	25.1	0.31				
Critical boom angle(°)	44		44		45		60	
Parts of line	1							
Standard hook	For 4ton							
Hook mass (kg)	60							

(Unit : Metric ton)

LIFTING CAPACITIES (12)

Based on ISO 4305

Not exceed 75 % static tipping loads

29.0 m Boom + 5.3 m Jib								
Outriggers intermediately extended (4.4m)					over side			
Boom angle (°)	Offset 7°		Offset 25°		Offset 45°		Offset 60°	
	Working radius (m)	Load (ton)	Working radius (m)	Load (ton)	Working radius (m)	Load (ton)	Working radius (m)	Load (ton)
84	4.2	3.00	6.1	3.00	7.3	1.90	7.7	1.25
82	5.5	3.00	7.4	2.95	8.4	1.90	8.8	1.25
79	7.5	3.00	9.2	2.65	10.1	1.80	10.5	1.25
76	9.5	3.00	11.0	2.40	11.8	1.70	12.1	1.20
73	11.3	2.75	12.6	2.15	13.4	1.65	13.6	1.20
70	12.9	2.05	14.2	1.80	15.0	1.60	15.1	1.20
67	14.4	1.60	15.6	1.40	16.5	1.30	16.6	1.20
64	15.9	1.20	17.0	1.10	17.8	1.05	17.9	1.05
61	17.3	0.94	18.4	0.87	19.1	0.81	19.2	0.81
58	18.7	0.71	19.8	0.65	20.3	0.63		
55	20.1	0.49	21.1	0.45	21.5	0.44		
Critical boom angle (°)	54		54		54		60	
Parts of line	1							
Standard hook	For 4ton							
Hook mass (kg)	60							

(Unit : Metric ton)

LIFTING CAPACITIES (13)

Based on ISO 4305

Not exceed 75 % static tipping loads

29.0 m Boom + 5.3 m Jib								
Outriggers intermediately extended (3.4m)					over side			
Boom angle (°)	Offset 7°		Offset 25°		Offset 45°		Offset 60°	
	Working radius (m)	Load (ton)	Working radius (m)	Load (ton)	Working radius (m)	Load (ton)	Working radius (m)	Load (ton)
84	4.2	3.00	6.1	3.00	7.3	1.90	7.7	1.25
82	5.5	3.00	7.4	2.95	8.4	1.90	8.8	1.25
79	7.5	3.00	9.2	2.65	10.1	1.80	10.5	1.25
76	9.5	2.55	11.0	2.10	11.8	1.70	12.1	1.20
73	11.0	1.85	12.4	1.60	13.4	1.40	13.6	1.20
70	12.6	1.30	13.9	1.15	14.8	1.05	15.1	1.05
67	14.1	0.92	15.3	0.83	16.2	0.76	16.5	0.76
Critical boom angle(°)	66		66		66		66	
Parts of line	1							
Standard hook	For 4ton							
Hook mass (kg)	60							

(Unit : Metric ton)

LIFTING CAPACITIES (14)

Based on ISO 4305

Not exceed 75 % static tipping loads

20.2 m Boom + 8.2 m Jib								
Outriggers fully extended (6.0m)				360° full range				
Boom angle (°)	Offset 7°		Offset 25°		Offset 45°		Offset 60°	
	Working radius (m)	Load (ton)	Working radius (m)	Load (ton)	Working radius (m)	Load (ton)	Working radius (m)	Load (ton)
84	3.4	2.30	5.9	1.55	8.0	0.95	9.0	0.70
82	4.4	2.30	6.9	1.45	8.9	0.95	9.8	0.70
79	5.9	2.20	8.2	1.35	10.2	0.92	11.1	0.70
76	7.3	2.10	9.6	1.25	11.4	0.90	12.2	0.69
73	8.8	2.00	11.0	1.15	12.6	0.87	13.3	0.68
70	10.2	1.85	12.3	1.10	13.8	0.85	14.4	0.67
67	11.6	1.65	13.5	1.05	15.0	0.84	15.4	0.67
64	12.9	1.50	14.8	1.00	16.0	0.82	16.4	0.67
61	14.2	1.40	15.9	0.99	17.1	0.81	17.3	0.66
58	15.4	1.30	17.0	0.96	18.0	0.81		
55	16.6	1.20	18.0	0.93	18.9	0.80		
53	17.3	1.15	18.7	0.91	19.5	0.80		
50	18.4	1.10	19.7	0.89	20.3	0.80		
46	19.8	1.05	20.9	0.87	21.3	0.79		
45	20.1	1.04	21.2	0.86				
40	21.6	0.98	22.5	0.84				
37	22.4	0.95	23.2	0.84				
35	22.9	0.89	23.6	0.84				
30	24.0	0.73	24.5	0.72				
26	24.8	0.61	25.1	0.60				
25	25.0	0.58						
20	25.7	0.49						
15	26.3	0.42						
10	26.6	0.37						
Critical boom angle(°)	9		25		45		60	
Parts of line	1							
Standard hook	For 4ton							
Hook mass (kg)	60							

(Unit : Metric ton)

LIFTING CAPACITIES (15)

Based on ISO 4305

Not exceed 75 % static tipping loads

20.2 m Boom + 8.2 m Jib								
Outriggers intermediately extended (5.2m)					over side			
Boom angle (°)	Offset 7°		Offset 25°		Offset 45°		Offset 60°	
	Working radius (m)	Load (ton)	Working radius (m)	Load (ton)	Working radius (m)	Load (ton)	Working radius (m)	Load (ton)
84	3.4	2.30	5.9	1.55	8.0	0.95	9.0	0.70
82	4.4	2.30	6.9	1.45	8.9	0.95	9.8	0.70
79	5.9	2.20	8.2	1.35	10.2	0.92	11.1	0.70
76	7.3	2.10	9.6	1.25	11.4	0.90	12.2	0.69
73	8.8	2.00	11.0	1.15	12.6	0.87	13.3	0.68
70	10.2	1.85	12.3	1.10	13.8	0.85	14.4	0.67
67	11.6	1.65	13.5	1.05	15.0	0.84	15.4	0.67
64	12.9	1.50	14.8	1.00	16.0	0.82	16.4	0.67
61	14.2	1.40	15.9	0.99	17.1	0.81	17.3	0.66
58	15.4	1.30	17.0	0.96	18.0	0.81		
55	16.6	1.20	18.0	0.93	18.9	0.80		
53	17.3	1.15	18.7	0.91	19.5	0.80		
50	18.4	1.10	19.7	0.89	20.3	0.80		
46	19.7	1.00	20.9	0.87	21.3	0.79		
45	20.0	0.98	21.2	0.86				
40	21.6	0.75	22.5	0.72				
37	22.4	0.65	23.2	0.63				
35	22.9	0.58	23.6	0.57				
30	24.0	0.43	24.5	0.43				
26	24.7	0.32	25.1	0.32				
25	24.9	0.30						
20	25.7	0.21						
Critical boom angle(°)	19		25		45		60	
Parts of line	1							
Standard hook	For 4ton							
Hook mass (kg)	60							

(Unit : Metric ton)

LIFTING CAPACITIES (16)

Based on ISO 4305

Not exceed 75 % static tipping loads

20.2 m Boom + 8.2 m Jib								
Outriggers intermediately extended (4.4m)					over side			
Boom angle (°)	Offset 7°		Offset 25°		Offset 45°		Offset 60°	
	Working radius (m)	Load (ton)	Working radius (m)	Load (ton)	Working radius (m)	Load (ton)	Working radius (m)	Load (ton)
84	3.4	2.30	5.9	1.55	8.0	0.95	9.0	0.70
82	4.4	2.30	6.9	1.45	8.9	0.95	9.8	0.70
79	5.9	2.20	8.2	1.35	10.2	0.92	11.1	0.70
76	7.3	2.10	9.6	1.25	11.4	0.90	12.2	0.69
73	8.8	2.00	11.0	1.15	12.6	0.87	13.3	0.68
70	10.2	1.85	12.3	1.10	13.8	0.85	14.4	0.67
67	11.6	1.65	13.5	1.05	15.0	0.84	15.4	0.67
64	12.9	1.50	14.8	1.00	16.0	0.82	16.4	0.67
61	14.2	1.40	15.9	0.99	17.1	0.81	17.3	0.66
58	15.4	1.30	17.0	0.96	18.0	0.81		
55	16.6	1.15	18.0	0.93	18.9	0.80		
53	17.3	1.00	18.7	0.91	19.5	0.80		
50	18.3	0.83	19.6	0.77	20.3	0.74		
46	19.7	0.63	20.9	0.59	21.3	0.59		
45	20.0	0.59	21.2	0.55				
40	21.5	0.37	22.5	0.36				
37	22.3	0.26	23.1	0.26				
35	22.8	0.20	23.5	0.20				
Critical boom angle(°)	34		34		45		60	
Parts of line	1							
Standard hook	For 4ton							
Hook mass (kg)	60							

(Unit : Metric ton)

LIFTING CAPACITIES (17)

Based on ISO 4305

Not exceed 75 % static tipping loads

20.2 m Boom + 8.2 m Jib								
Outriggers intermediately extended (3.4m)					over side			
Boom angle (°)	Offset 7°		Offset 25°		Offset 45°		Offset 60°	
	Working radius (m)	Load (ton)	Working radius (m)	Load (ton)	Working radius (m)	Load (ton)	Working radius (m)	Load (ton)
84	3.4	2.30	5.9	1.55	8.0	0.95	9.0	0.70
82	4.4	2.30	6.9	1.45	8.9	0.95	9.8	0.70
79	5.9	2.20	8.2	1.35	10.2	0.92	11.1	0.70
76	7.3	2.10	9.6	1.25	11.4	0.90	12.2	0.69
73	8.8	2.00	11.0	1.15	12.6	0.87	13.3	0.68
70	10.2	1.85	12.3	1.10	13.8	0.85	14.4	0.67
67	11.6	1.65	13.5	1.05	15.0	0.84	15.4	0.67
64	12.9	1.30	14.8	1.00	16.0	0.82	16.4	0.67
61	14.1	1.00	15.9	0.85	17.1	0.79	17.3	0.66
58	15.3	0.76	17.0	0.66	18.0	0.62		
55	16.4	0.57	18.0	0.50	18.9	0.48		
Critical boom angle (°)	54		54		54		60	
Parts of line	1							
Standard hook	For 4ton							
Hook mass (kg)	60							

(Unit : Metric ton)

LIFTING CAPACITIES (18)

Based on ISO 4305

Not exceed 75 % static tipping loads

29.0 m Boom + 8.2 m Jib								
Outriggers fully extended (6.0m)					360° full range			
Boom angle (°)	Offset 7°		Offset 25°		Offset 45°		Offset 60°	
	Working radius (m)	Load (ton)	Working radius (m)	Load (ton)	Working radius (m)	Load (ton)	Working radius (m)	Load (ton)
84	5.1	2.30	7.5	1.45	9.5	0.90	10.5	0.70
82	6.5	2.25	8.8	1.40	10.7	0.90	11.6	0.70
79	8.6	2.15	10.7	1.30	12.5	0.90	13.3	0.69
76	10.7	2.00	12.6	1.25	14.2	0.86	14.9	0.68
73	12.6	1.85	14.4	1.15	15.9	0.84	16.5	0.67
70	14.5	1.70	16.2	1.10	17.6	0.82	18.0	0.66
67	16.3	1.55	17.9	1.05	19.1	0.81	19.4	0.66
64	18.0	1.40	19.5	0.97	20.6	0.80	20.8	0.66
61	19.6	1.25	21.1	0.93	22.1	0.80	22.1	0.64
58	21.2	1.15	22.6	0.91	23.4	0.79		
55	22.6	1.00	24.1	0.88	24.7	0.79		
53	23.5	0.90	25.0	0.83	25.5	0.79		
50	24.9	0.74	26.2	0.69	26.6	0.69		
46	26.6	0.54	27.7	0.51	27.9	0.51		
45	26.9	0.49	28.0	0.47				
40	28.8	0.30	29.7	0.30				
37	29.8	0.21	30.6	0.21				
Critical boom angle(°)	36		36		45		60	
Parts of line	1							
Standard hook	For 4ton							
Hook mass (kg)	60							

(Unit : Metric ton)

LIFTING CAPACITIES (19)

Based on ISO 4305

Not exceed 75 % static tipping loads

29.0 m Boom + 8.2 m Jib								
Outriggers intermediately extended (5.2m)					over side			
Boom angle (°)	Offset 7°		Offset 25°		Offset 45°		Offset 60°	
	Working radius (m)	Load (ton)	Working radius (m)	Load (ton)	Working radius (m)	Load (ton)	Working radius (m)	Load (ton)
84	5.1	2.30	7.5	1.45	9.5	0.90	10.5	0.70
82	6.5	2.25	8.8	1.40	10.7	0.90	11.6	0.70
79	8.6	2.15	10.7	1.30	12.5	0.90	13.3	0.69
76	10.7	2.00	12.6	1.25	14.2	0.86	14.9	0.68
73	12.6	1.85	14.4	1.15	15.9	0.84	16.5	0.67
70	14.5	1.70	16.2	1.10	17.6	0.82	18.0	0.66
67	16.3	1.55	17.9	1.05	19.1	0.81	19.4	0.66
64	18.0	1.40	19.5	0.97	20.6	0.80	20.8	0.66
61	19.6	1.15	21.1	0.93	22.1	0.80	22.1	0.64
58	20.9	0.97	22.6	0.84	23.4	0.79		
55	22.4	0.76	23.9	0.68	24.6	0.67		
53	23.4	0.63	24.8	0.59	25.4	0.58		
50	24.7	0.46	26.0	0.44	26.5	0.44		
Critical boom angle(°)	49		49		49		60	
Parts of line	1							
Standard hook	For 4ton							
Hook mass (kg)	60							

(Unit : Metric ton)

LIFTING CAPACITIES (20)

Based on ISO 4305

Not exceed 75 % static tipping loads

29.0 m Boom + 8.2 m Jib								
Outriggers intermediately extended (4.4m)					over side			
Boom angle (°)	Offset 7°		Offset 25°		Offset 45°		Offset 60°	
	Working radius (m)	Load (ton)	Working radius (m)	Load (ton)	Working radius (m)	Load (ton)	Working radius (m)	Load (ton)
84	5.1	2.30	7.5	1.45	9.5	0.90	10.5	0.70
82	6.5	2.25	8.8	1.40	10.7	0.90	11.6	0.70
79	8.6	2.15	10.7	1.30	12.5	0.90	13.3	0.69
76	10.7	2.00	12.6	1.25	14.2	0.86	14.9	0.68
73	12.6	1.85	14.4	1.15	15.9	0.84	16.5	0.67
70	14.5	1.65	16.2	1.10	17.6	0.82	18.0	0.66
67	16.2	1.35	17.9	1.05	19.1	0.81	19.4	0.66
64	17.7	1.05	19.5	0.90	20.6	0.80	20.8	0.66
61	19.2	0.81	20.8	0.72	22.0	0.67	22.1	0.64
58	20.7	0.61	22.3	0.52	23.2	0.51		
Critical boom angle (°)	57		57		57		60	
Parts of line	1							
Standard hook	For 4ton							
Hook mass (kg)	60							

(Unit : Metric ton)

LIFTING CAPACITIES (21)

Based on ISO 4305

Not exceed % of static tipping loads

29.0 m Boom + 8.2 m Jib								
Outriggers intermediately extended (3.4m)					over side			
Boomangle ()	Offset 7°		Offset 25°		Offset 45°		Offset 60°	
	Working radius (m)	Load (ton)	Working radius (m)	Load (ton)	Working radius (m)	Load (ton)	Working radius (m)	Load (ton)
84	5.1	2.30	7.5	1.45	9.5	0.90	10.5	0.70
82	6.5	2.25	8.8	1.40	10.7	0.90	11.6	0.70
79	8.6	2.15	10.7	1.30	12.5	0.90	13.3	0.69
76	10.7	2.00	12.6	1.25	14.2	0.86	14.9	0.68
73	12.5	1.55	14.4	1.15	15.9	0.84	16.5	0.67
70	14.1	1.10	16.1	0.93	17.6	0.82	18.0	0.66
67	15.8	0.77	17.7	0.64	19.0	0.60	19.4	0.62
Critical boom angle(°)	66		66		66		66	
Parts of line	1							
Standard hook	For 4ton							
Hook mass (kg)	60							

(Unit : Metric ton)

LIFTING CAPACITIES (22)

Based on ISO 4305

Not exceed 75 % static tipping loads

Searcher hook (LOW POSITION)

Working radius(m)	Outriggers fully extended (6.0m) 360° full range					
	6.7m Boom	11.25m Boom	15.74m Boom	20.2m Boom	24.6m Boom	29.0m Boom
2.8	7.50					
3.0	7.50					
3.5	7.50					
4.0	7.50	7.50				
4.5	7.50	7.50				
5.0	7.50	7.50				
5.5	7.50	7.50	7.50			
6.0	7.50	7.50	7.50			
6.5	7.50(6.3m)	7.50	7.50			
7.0		7.50	7.50	7.50		
8.0		6.70	6.65	6.85		
9.0		5.30	5.25	5.45	5.65	
10.0		4.25	4.20	4.45	4.65	4.35
11.0		3.60(10.8m)	3.45	3.65	3.85	4.00
12.0			2.85	3.10	3.25	3.40
13.0			2.35	2.60	2.80	2.90
14.0			1.95	2.20	2.40	2.50
15.0			1.60	1.90	2.05	2.20
16.0			1.55(15.2m)	1.60	1.80	1.90
17.0				1.35	1.55	1.65
18.0				1.10	1.30	1.45
19.0				0.90	1.10	1.25
20.0				0.80(19.6m)	0.95	1.10
21.0					0.80	0.90
22.0					0.65	0.80
23.0					0.50	0.65
24.0					0.40(23.9m)	0.55
25.0						0.45
26.0						0.35
27.0						0.25
28.0						0.15
29.0						0.15(28.3m)
Critical boom angle(°)	-	-	-	-	-	-

(Unit : Metric ton)

LIFTING CAPACITIES (23)

Based on ISO 4305

Not exceed 75 % static tipping loads

Searcher hook (LOW POSITION)

Working radius(m)	Outriggers intermediately extended (5.2m)			over side		
	6.7m Boom	11.25m Boom	15.74m Boom	20.2m Boom	24.6m Boom	29.0m Boom
2.8	7.50					
3.0	7.50					
3.5	7.50					
4.0	7.50	7.50				
4.5	7.50	7.50				
5.0	7.50	7.50				
5.5	7.50	7.50	7.50			
6.0	7.50	7.50	7.50			
6.5	7.50(6.3m)	7.50	7.50			
7.0		6.75	6.60	6.80		
8.0		5.20	5.05	5.30		
9.0		4.10	4.00	4.20	4.40	
10.0		3.30	3.25	3.45	3.60	3.75
11.0		2.80(10.8m)	2.65	2.85	3.00	3.15
12.0			2.15	2.35	2.55	2.70
13.0			1.75	2.00	2.15	2.30
14.0			1.40	1.70	1.85	1.95
15.0			1.10	1.40	1.55	1.70
16.0			1.05(15.2m)	1.15	1.35	1.45
17.0				0.95	1.10	1.25
18.0				0.75	0.95	1.05
19.0				0.55	0.75	0.90
20.0				0.45(19.6m)	0.60	0.75
21.0					0.50	0.60
22.0					0.35	0.50
23.0					0.25	0.40
24.0					0.15(23.9m)	0.30
25.0						0.20
26.0						0.10
Critical boom angle(°)	-	-	-	-	-	25

(Unit : Metric ton)

LIFTING CAPACITIES (24)

Based on ISO 4305

Not exceed 75 % static tipping loads

Searcher hook (LOW POSITION)

Working radius(m)	Outriggers intermediately extended (4.4m)			over side		
	6.7m Boom	11.25m Boom	15.74m Boom	20.2m Boom	24.6m Boom	29.0m Boom
2.8	7.50					
3.0	7.50					
3.5	7.50					
4.0	7.50	7.50				
4.5	7.50	7.50				
5.0	7.50	7.50				
5.5	7.50	7.50	7.50			
6.0	6.90	6.70	6.60			
6.5	6.25(6.3m)	5.75	5.65			
7.0		5.00	4.90	5.05		
8.0		3.85	3.75	3.95		
9.0		3.00	2.95	3.15	3.30	
10.0		2.40	2.35	2.55	2.70	2.85
11.0		2.00(10.8m)	1.85	2.10	2.25	2.35
12.0			1.50	1.70	1.85	2.00
13.0			1.15	1.40	1.55	1.70
14.0			0.85	1.10	1.30	1.45
15.0			0.60	0.90	1.10	1.20
16.0			0.55(15.2m)	0.70	0.85	1.00
17.0				0.50	0.70	0.80
18.0				0.35	0.55	0.65
19.0				0.20	0.40	0.50
20.0				0.10(19.6m)	0.25	0.40
21.0					0.15	0.30
22.0						0.20
23.0						0.10
Critical boom angle(°)	-	-	-	-	30	37

(Unit : Metric ton)

LIFTING CAPACITIES (25)

Based on ISO 4305

Not exceed 75 % static tipping loads

Searcher hook (LOW POSITION)

Working radius(m)	Outriggers intermediately extended (3.4m)			over side		
	6.7m Boom	11.25m Boom	15.74m Boom	20.2m Boom	24.6m Boom	29.0m Boom
2.8	7.50					
3.0	7.50					
3.5	7.50					
4.0	7.50	7.50				
4.5	7.20	7.05				
5.0	5.90	5.75				
5.5	4.95	4.80	4.70			
6.0	4.20	4.05	3.95			
6.5	3.80(6.3m)	3.50	3.40			
7.0		3.00	2.90	3.10		
8.0		2.30	2.20	2.40		
9.0		1.75	1.70	1.85	2.00	
10.0		1.35	1.30	1.45	1.60	1.75
11.0		1.05(10.8m)	0.95	1.15	1.30	1.40
12.0			0.65	0.85	1.05	1.15
13.0			0.40	0.65	0.80	0.95
14.0			0.20	0.45	0.60	0.75
15.0				0.25	0.45	0.55
16.0				0.10	0.30	0.40
17.0						0.30
Critical boom angle(°)	-	-	22	36	49	54

(Unit : Metric ton)

LIFTING CAPACITIES (26)

Based on ISO 4305

Not exceed 75 % static tipping loads

Searcher hook (LOW POSITION)

Outriggers completely retracted (2.085m)		over side				
Working radius(m)	6.7m Boom	11.25m Boom	15.74m Boom	20.2m Boom	24.6m Boom	29.0m Boom
2.8	7.50					
3.0	6.60					
3.5	5.05					
4.0	4.00	3.85				
4.5	3.25	3.10				
5.0	2.65	2.55				
5.5	2.20	2.10	2.00			
6.0	1.85	1.75	1.65			
6.5	1.65(6.3m)	1.45	1.40			
7.0		1.20	1.15	1.30		
8.0		0.80	0.75	0.95		
9.0		0.45	0.40	0.60	0.75	
10.0		0.20				0.50
Critical boom angle(°)	-	19	53	62	68	69

(Unit : Metric ton)

LIFTING CAPACITIES (27)

Based on ISO 4305

Not exceed 75 % static tipping loads

Searcher hook (HIGH POSITION)

Outriggers fully extended (6.0m) 360° full range						
Working radius(m)	6.7m Boom	11.25m Boom	15.74m Boom	20.2m Boom	24.6m Boom	29.0m Boom
2.8						
3.0						
3.5						
4.0						
4.5						
5.0						
5.5	7.50					
6.0	7.50					
6.5	7.50(6.2m)					
7.0						
8.0						
9.0		5.15				
10.0		4.15				
11.0		3.60(10.7m)				
12.0						
13.0			2.30			
14.0			1.90			
15.0			1.55			
16.0			1.50(15.2m)			
17.0				1.30		
18.0				1.05		
19.0				0.90		
20.0				0.75(19.7m)	0.90	
21.0					0.75	
22.0					0.60	
23.0					0.50	
24.0					0.40	0.50
25.0					0.35(24.1m)	0.40
26.0						0.30
27.0						0.25
28.0						0.15
29.0						0.10(28.5m)
Critical boom angle(°)	-	-	-	-	-	-

(Unit : Metric ton)

LIFTING CAPACITIES (28)

Based on ISO 4305

Not exceed 75 % static tipping loads

Searcher hook (HIGH POSITION)

Working radius(m)	Outriggers intermediately extended (5.2m)			over side		
	6.7m Boom	11.25m Boom	15.74m Boom	20.2m Boom	24.6m Boom	29.0m Boom
2.8						
3.0						
3.5						
4.0						
4.5						
5.0						
5.5	7.50					
6.0	7.50					
6.5	7.50(6.2m)					
7.0						
8.0						
9.0		4.00				
10.0		3.25				
11.0		2.80(10.7m)				
12.0						
13.0			1.70			
14.0			1.35			
15.0			1.10			
16.0			1.00(15.2m)			
17.0				0.90		
18.0				0.70		
19.0				0.55		
20.0				0.45(19.7m)	0.60	
21.0					0.45	
22.0					0.35	
23.0					0.25	
24.0					0.15	0.25
25.0					0.15(24.1m)	0.15
26.0						0.10
Critical boom angle(°)	-	-	-	-	-	23

(Unit : Metric ton)

LIFTING CAPACITIES (29)

Based on ISO 4305

Not exceed 75 % static tipping loads

Searcher hook (HIGH POSITION)

Working radius(m)	Outriggers intermediately extended (4.4m)			over side		
	6.7m Boom	11.25m Boom	15.74m Boom	20.2m Boom	24.6m Boom	29.0m Boom
2.8						
3.0						
3.5						
4.0						
4.5						
5.0						
5.5	7.50					
6.0	7.15					
6.5	6.70(6.2m)					
7.0						
8.0						
9.0		2.90				
10.0		2.35				
11.0		2.00(10.7m)				
12.0						
13.0			1.10			
14.0			0.80			
15.0			0.55			
16.0			0.50(15.2m)			
17.0				0.45		
18.0				0.30		
19.0				0.15		
20.0				0.10(19.7m)	0.20	
21.0					0.10	
Critical boom angle(°)	-	-	-	-	28	

(Unit : Metric ton)

LIFTING CAPACITIES (30)

Based on ISO 4305

Not exceed 75 % static tipping loads

Searcher hook (HIGH POSITION)

Working radius(m)	Outriggers intermediately extended (3.4m)			over side		
	6.7m Boom	11.25m Boom	15.74m Boom	20.2m Boom	24.6m Boom	29.0m Boom
2.8						
3.0						
3.5						
4.0						
4.5						
5.0						
5.5	4.80					
6.0	4.10					
6.5	3.85(6.2m)					
7.0						
8.0						
9.0		1.65				
10.0		1.30				
11.0		1.05(10.7m)				
12.0						
13.0			0.35			
14.0			0.15			
Critical boom angle(°)	-	-	20			

(Unit : Metric ton)

LIFTING CAPACITIES (31)

Based on ISO 4305

Not exceed 75 % static tipping loads

Searcher hook (HIGH POSITION)

Outriggers completely retracted (2.085m)		over side				
Working radius(m)	6.7m Boom	11.25m Boom	15.74m Boom	20.2m Boom	24.6m Boom	29.0m Boom
2.8						
3.0						
3.5						
4.0						
4.5						
5.0						
5.5	2.10					
6.0	1.75					
6.5	1.65(6.2m)					
7.0						
8.0						
9.0		0.40				
10.0		0.15				
Critical boom angle(°)	-	16				

(Unit : Metric ton)

Notes for the lifting capacity chart

When the outriggers are used

1. The lifting capacity chart indicates the maximum load which can be lifted by this crane provided it is level and standing on firm level ground. The values in the chart include the mass of the main hook and slings for boom operation, and auxiliary hook and slings for jib operation.
The values in the chart are values with the main and auxiliary hooks removed and main and auxiliary wire ropes stowed for searcher hook operation.
[25 ton hook (mass: 220kg), 4 ton hook (mass: 60kg)]
Within the chart the figures in the area bordered with a thick line are based on structural limitations while other figures are determined by stability limitations.
2. The working radii are the actual values allowing for boom and jib deflection. Therefore you must always operate the crane on the basis of working radius.
3. The jib working radii are based on the jib mounted on the end of 20.2m boom or the 29.0m boom.
If the boom is at any other length (more than 20.2m and less than 29.0m), use the boom angle for the 29.0m boom alone as the criterion.
If the boom length is less than 20.2m, use the boom angle for the 20.2m boom alone as the criterion.
4. Do not operate the jib when the outriggers are completely retracted.
5. The lifting capacities for the over sides vary with the outriggers extension width. Therefore for each outriggers extension condition you should work according the lifting capacity chart. Use the lifting capacity chart of outriggers full extension for both front and rear areas lifting capacities.

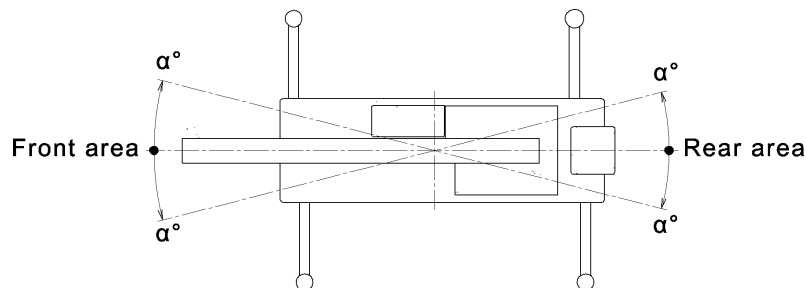

Outrigger extension status	Intermediate extension (5.2m)	Intermediate extension (4.4m)	Intermediate extension (3.4m)	Complete retraction
Area α°	35	30	20	3

6. The lifting capacity of the rooster sheave is the lifting capacity of the boom minus the mass of all attached hook, slings etc. to the boom, with an upper limit of 4,000 kg.
[The hook for use with the rooster sheave is the 4 ton hook (mass: 60 kg) with one part of line.]
7. If the boom length, boom angle, working radius, jib length and/or jib angle exceeds the rated value, use the lifting capacity for the rated value or for the next one, whichever gives the smaller lifting capacity.

8. If you are working with the boom while the jib is rigged, subtract 2000 kg plus the mass of all attached hook, slings, etc. to the boom from the each lifting capacity of the boom, with an upper limit of 10 ton.
Do not use the rooster sheave in this situation. And do not operate the boom while the jib is rigged, when the outriggers are completely retracted.
9. If you are working with the boom while the searcher hook is rigged, subtract 110 kg plus the mass of all attached hook, slings, etc. to the boom from each lifting capacity of the boom.
10. The lifting load with which you can extend or retract the boom during searcher hook operation may become smaller than the lifting capacity depending on the conditions such as the oil pressure, boom angle, lubricating state to the boom, etc.
11. In whatever working conditions the corresponding boom critical angle is shown in the chart. The crane can tip over if the boom is lowered below the critical angle even if unloaded. Therefore, never lower the boom below these angles.
12. The standard parts of line for each boom length are as indicated in the chart. If you work with a nonstandard number of parts of line, do not exceed 37.2 kN (3.8 tf) per wire rope respectively.
13. If you work with 7 parts of line on the hook (with * marked in the lifting capacity chart), use the rooster sheave.
14. High-speed winch operation should only be performed to allow descent of the hook alone. Avoid sudden lever operation.
15. Crane operation is permissible up to a wind speed of 10m/s. Even in relatively light wind conditions, extra care should be taken when handling loads presenting large wind catching areas.
16. The boom guard must be removed during crane operation.
17. If you work with a load in excess of the lifting capacity or use incorrect working procedures, you are risking damaging the crane or tipping it over. In such cases, the crane will not be guaranteed.

LIFTING CAPACITIES(32)

Based on ISO 4305

Not exceed 75 % static tipping loads

Stationary on rubber						
Working radius(m)	6.7m Boom		11.25m Boom		15.74m Boom	
	Over front	360° full range	Over front	360° full range	Over front	360° full range
3.0	8.50	6.00	8.50	5.50	7.50	5.20
3.5	8.50	4.50	8.50	4.10	7.50	3.80
4.0	8.50	3.30	8.50	3.20	7.50	3.00
4.5	7.50	2.55	7.20	2.55	6.50	2.40
5.0			6.10	2.00	5.40	1.90
5.5			5.10	1.55	4.55	1.50
6.0			4.25	1.20	3.85	1.15
6.5			3.55	0.90	3.30	0.85
7.0			3.00	0.65	2.80	
8.0			2.15		2.05	
9.0			1.55		1.50	
10.0					1.00	
11.0					0.60	
Critical boom angle(°)	-	-	-	37	35	61
Parts of line	4					
Standard hook	For 25ton					
Hook mass (kg)	220					

(Unit : Metric ton)

LIFTING CAPACITIES(33)

Based on ISO 4305

Not exceed 75 % static tipping loads

Pick & carry (less than 2 km/h)						
Working radius(m)	6.7m Boom		11.25m Boom		15.74m Boom	
	Over front	360° full range	Over front	360° full range	Over front	360° full range
3.0	6.80	4.80	6.40	4.40	5.90	4.00
3.5	6.80	3.60	6.40	3.30	5.90	3.00
4.0	6.80	2.65	6.40	2.55	5.90	2.40
4.5	6.00	2.05	5.50	2.05	5.00	1.90
5.0			4.75	1.50	4.30	1.40
5.5			4.10	1.05	3.65	1.00
6.0			3.40	0.65	3.10	0.60
6.5			2.85		2.65	
7.0			2.40		2.25	
8.0			1.65		1.60	
9.0			1.00		1.00	
10.0					0.50	
Critical boom angle(°)	-	-	-	48	42	62
Parts of line	4					
Standard hook	For 25ton					
Hook mass (kg)	220					

(Unit : Metric ton)

LIFTING CAPACITIES(34)

Based on ISO 4305

Not exceed 75 % static tipping loads

Searcher hook (LOW POSITION)

Stationary on rubber						
Working radius(m)	6.7m Boom		11.25m Boom		15.74m Boom	
	Over front	360° full range	Over front	360° full range	Over front	360° full range
2.8	7.50	6.80				
3.0	7.50	6.00				
3.5	7.50	4.60				
4.0	7.50	3.60	7.50	3.45		
4.5	7.30	2.95	7.30	2.80		
5.0	6.00	2.40	6.00	2.25		
5.5	5.05	2.00	5.00	1.85	4.95	1.80
6.0	4.35	1.65	4.30	1.55	4.25	1.45
6.5	3.95(6.3m)	1.50(6.3m)	3.70	1.30	3.65	1.20
7.0			3.20	1.05	3.15	1.00
8.0			2.50	0.70	2.45	0.60
9.0			1.95	0.35	1.90	
10.0			1.55	0.10	1.50	
11.0			1.25(10.8m)		1.20	
12.0					0.95	
13.0					0.70	
14.0					0.50	
15.0					0.30	
16.0					0.25(15.2m)	
Critical boom angle(°)	-	-	-	19	-	57

(Unit : Metric ton)

LIFTING CAPACITIES(35)

Based on ISO 4305

Not exceed 75 % static tipping loads

Searcher hook (LOW POSITION)

Pick & carry (less than 2 km/h)						
Working radius(m)	6.7m Boom		11.25m Boom		15.74m Boom	
	Over front	360° full range	Over front	360° full range	Over front	360° full range
2.8	7.50	5.20				
3.0	7.50	4.60				
3.5	7.50	3.50				
4.0	7.00	2.80	7.00	2.65		
4.5	5.60	2.25	5.60	2.10		
5.0	4.65	1.85	4.60	1.75		
5.5	3.90	1.55	3.85	1.40	3.80	1.35
6.0	3.35	1.25	3.30	1.20	3.25	1.10
6.5	3.05(6.3m)	1.15(6.3m)	2.85	1.00	2.80	0.90
7.0			2.45	0.80	2.45	0.75
8.0			1.90	0.55	1.85	
9.0			1.50	0.35	1.45	
10.0			1.20	0.10	1.15	
11.0			0.95(10.8m)		0.90	
12.0					0.70	
13.0					0.55	
14.0					0.40	
15.0					0.30	
16.0					0.25(15.2m)	
Critical boom angle(°)	-	-	-	19	-	61

(Unit : Metric ton)

LIFTING CAPACITIES(36)

Based on ISO 4305

Not exceed 75 % static tipping loads

Searcher hook (HIGH POSITION)

Stationary on rubber						
Working radius(m)	6.7m Boom		11.25m Boom		15.74m Boom	
	Over front	360° full range	Over front	360° full range	Over front	360° full range
2.8						
3.0						
3.5						
4.0						
4.5						
5.0						
5.5	5.05	1.85				
6.0	4.30	1.55				
6.5	4.05(6.2m)	1.45(6.2m)				
7.0						
8.0						
9.0			1.85	0.30		
10.0			1.50			
11.0			1.25(10.7m)			
12.0						
13.0					0.65	
14.0					0.45	
15.0					0.25	
16.0					0.20(15.2m)	
Critical boom angle(°)	-	-	-	29	-	

(Unit : Metric ton)

LIFTING CAPACITIES(37)

Based on ISO 4305

Not exceed 75 % static tipping loads

Searcher hook (HIGH POSITION)

Pick & carry (less than 2 km/h)						
Working radius(m)	6.7m Boom		11.25m Boom		15.74m Boom	
	Over front	360° full range	Over front	360° full range	Over front	360° full range
2.8						
3.0						
3.5						
4.0						
4.5						
5.0						
5.5	3.85	1.45				
6.0	3.30	1.20				
6.5	3.15(6.2m)	1.10(6.2m)				
7.0						
8.0						
9.0			1.45	0.30		
10.0			1.15			
11.0			0.95(10.7m)			
12.0						
13.0						
14.0						
15.0						
16.0						
Critical boom angle(°)	-	-	-	29		

(Unit : Metric ton)

Notes for the lifting capacity chart

When the outriggers are not used

1. The lifting capacity chart indicates the maximum load the crane can lift when its body is level on firm level ground with all tires inflated to the rated pressure and suspension cylinder completely retracted.
The values in the chart include the mass of the main hook and slings.
The values in the chart are values with the main and auxiliary hooks removed and main and auxiliary wire ropes stowed for searcher hook operation.
Within the chart the figures in the area bordered with a thick line are based on structural limitations while other figures are determined by stability limitations.
[Rated tire pressure: 900kPa (9.0bar)]
2. The working radii are the actual values allowing for boom deflection. Therefore you must always operate the crane on the basis of the working radius.
3. The lifting capacity differs between the front area capacity and the full range capacity. When slewing from the front to the side, take care that the crane could not be over loaded.

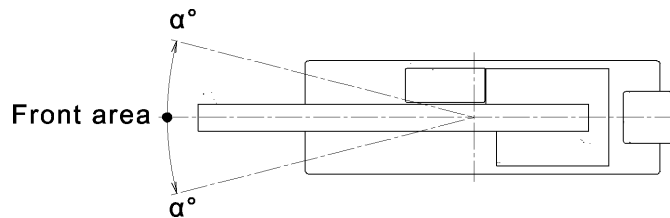

Crane operation	Stationary crane-on-rubber operation	Pick and carry operation
Area α°	1	1

4. The lifting capacity of the rooster sheave is the lifting capacity of the boom minus the mass of all attached hook, slings etc. to the boom, with an upper limit of 4,000 kg.
[The hook for use with the rooster sheave is the 4 ton hook (mass: 60 kg) with one part of line.]
5. Work within the capacity indicated in the lifting capacity chart.
6. For stationary crane-on-rubber operation, the parking brake and service brake lock device must be engaged.
7. For pick and carry operation, the high/low speed switch must be switched to "ON" (low range) and the shift switch set to speed 1.
8. For pick and carry operation, lower the load to just above the ground and keep your speed strictly below 2 km/h to avoid swinging the load.
Take particular care to avoid sharp turns, sudden starts and stops.
9. Never operate the crane during pick and carry operation. The slewing brake must be applied.
10. If the boom length, boom angle and/or working radius exceeds the rated value, use the lifting capacity for the rated value or for the next one, whichever gives the smaller lifting capacity.
11. The lifting load with which you can extend or retract the boom during searcher hook operation may become smaller than the lifting capacity depending on the conditions such as the oil pressure, boom angle, lubricating state to the boom, etc.

12. In whatever working conditions the corresponding boom critical angle is shown in the chart. The crane can tip over if the boom is lowered below the critical angle even if unloaded. Therefore, never lower the boom below these angles.
13. The standard parts of line for each boom length are as indicated in the chart. If you work with a non-standard number of parts of line, do not exceed 37.2 kN (3.8 tf) per wire rope respectively.
14. High-speed lowering operation should only be performed to allow descent of the hook alone. Avoid sudden lever operation.
15. Crane operation is permissible up to a wind speed of 10 m/s. Even in relatively light wind conditions, extra care should be taken when handling loads presenting large wind catching areas.
16. The boom guard must be removed during crane operation.
17. If you work with a load in excess of the rated lifting capacity or use incorrect working procedures, you are risking damaging the crane or tipping it over. In such cases, the crane will not be guaranteed.

WORKING RANGE

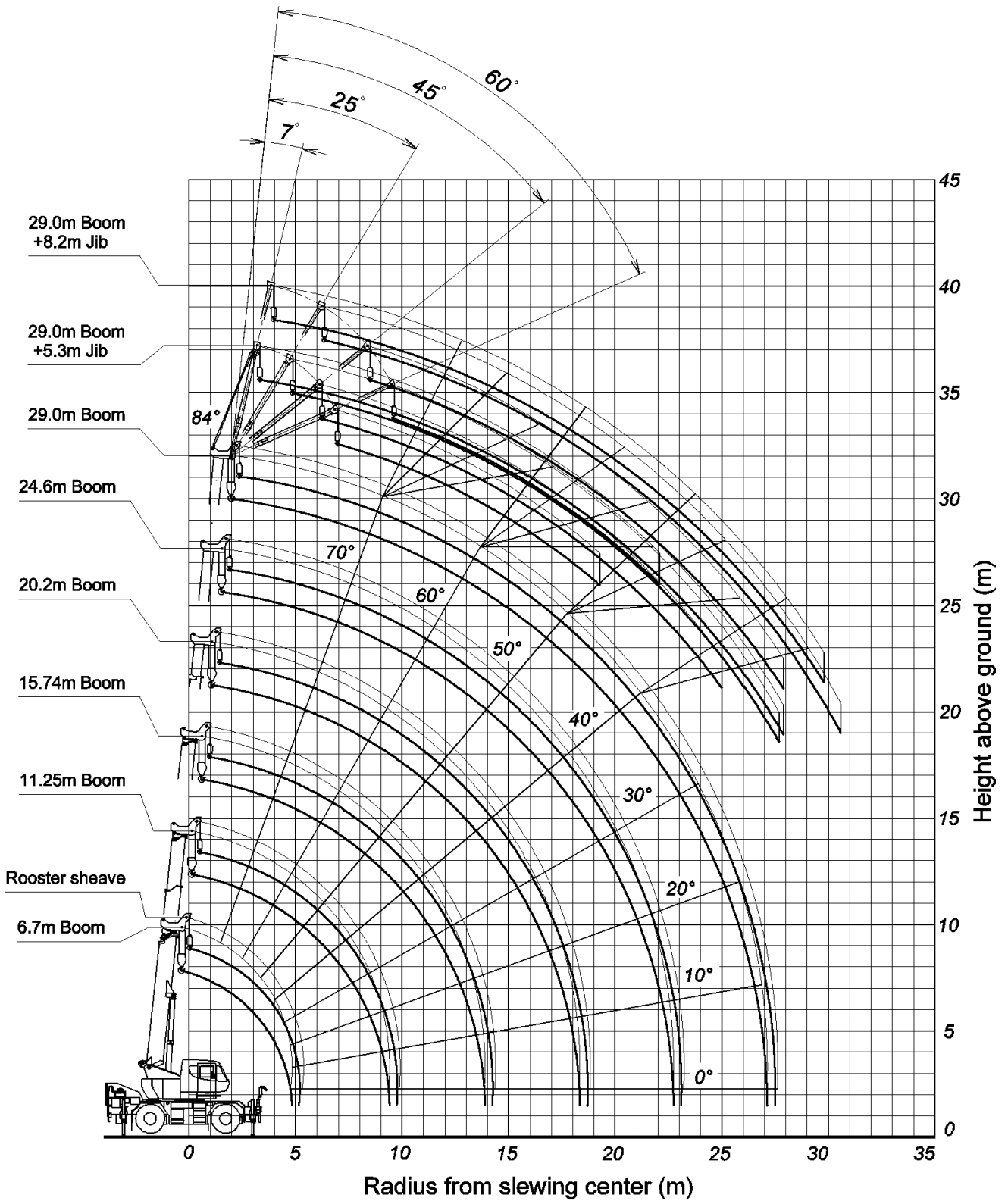

Note: 1. This diagram does not include deflection of Boom and Jib.
 2. The outriggers are fully extended.

WORKING RANGE

LOW POSITION

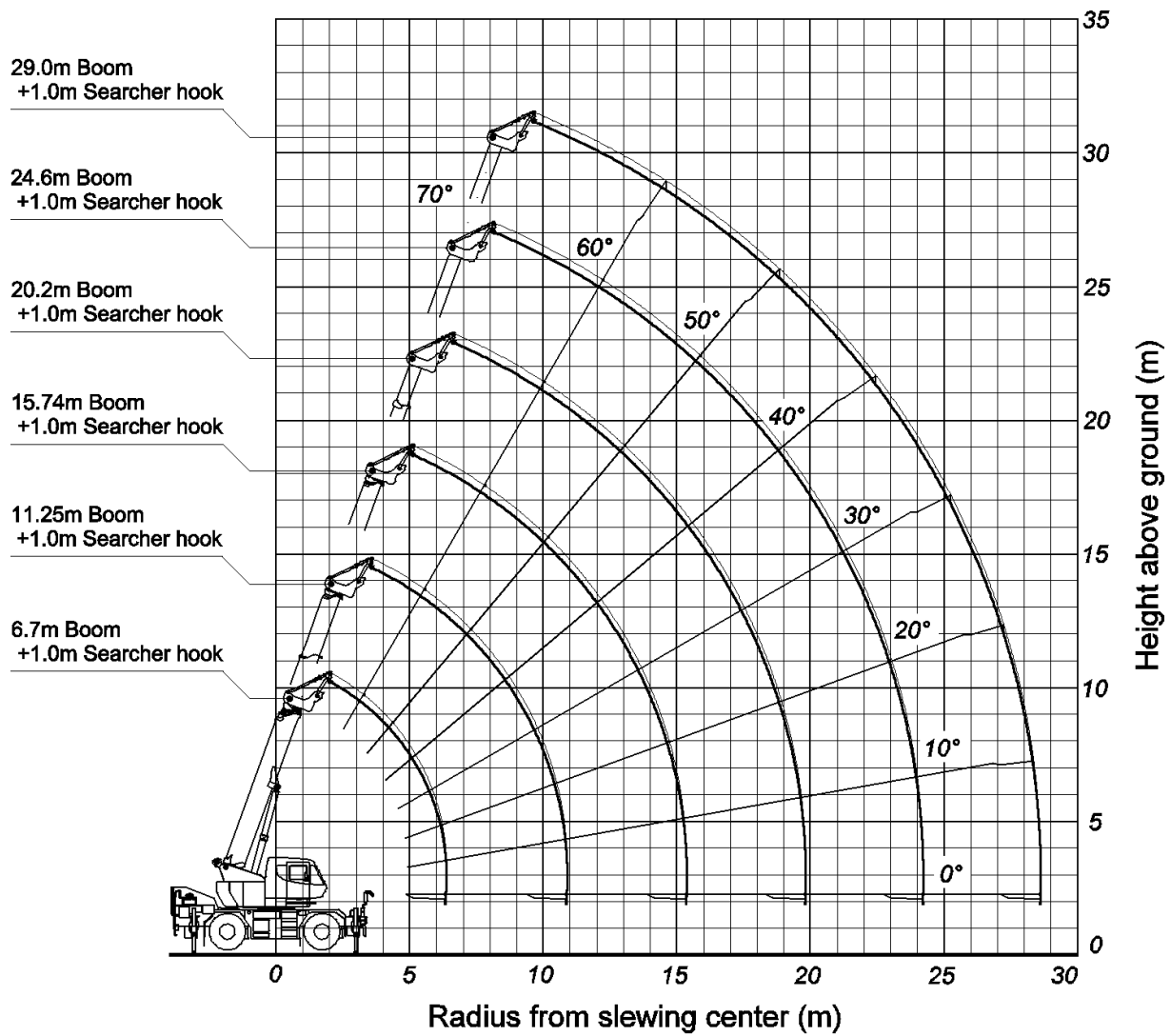

Note:1.This diagram does not include deflection of Boom and Searcher hook.
 2.The outriggers are fully extended.

WORKING RANGE

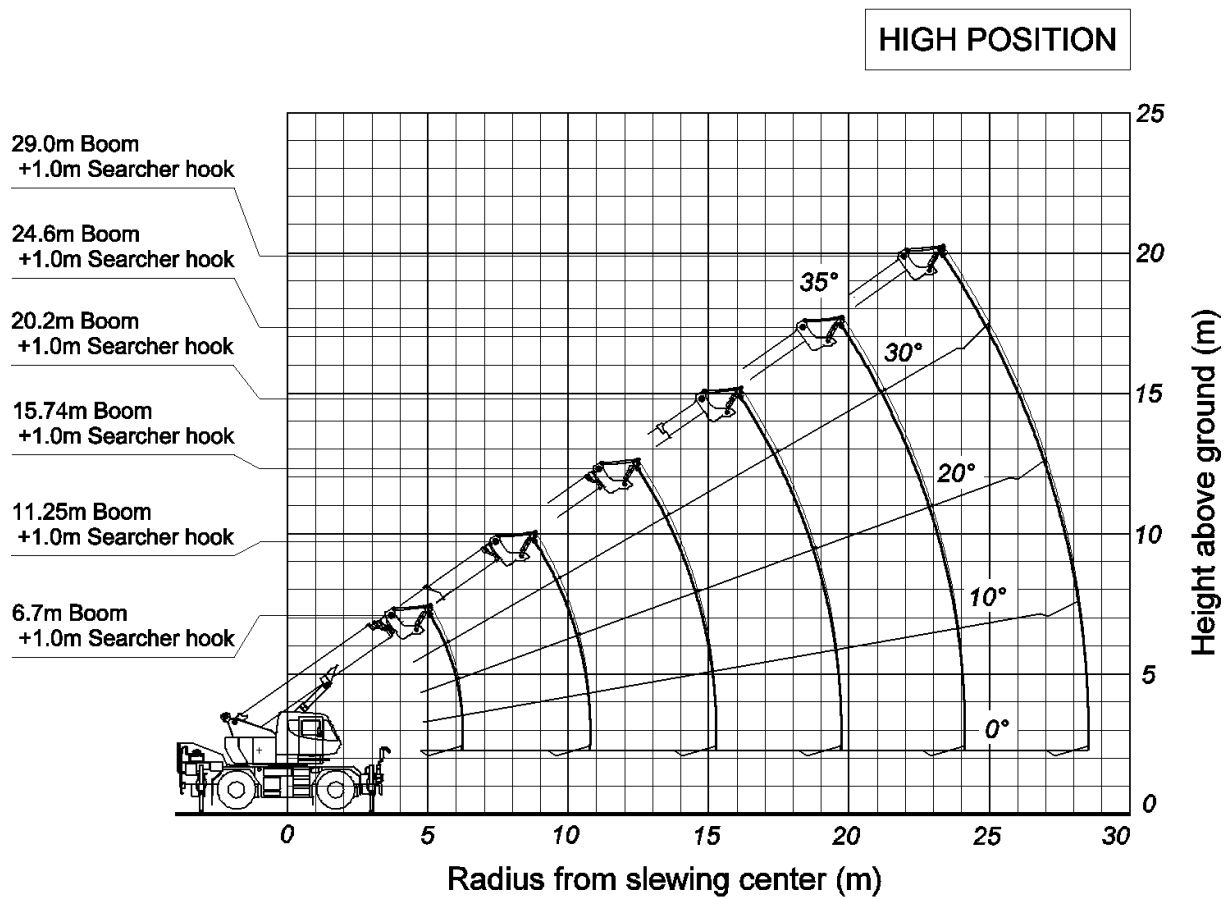

Note: 1. This diagram does not include deflection of Boom and Searcher hook.
 2. The outriggers are fully extended.

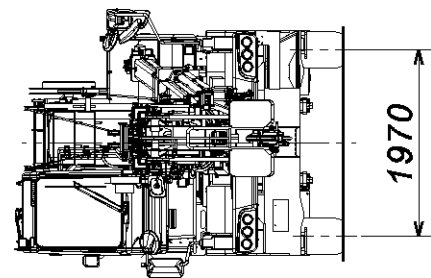
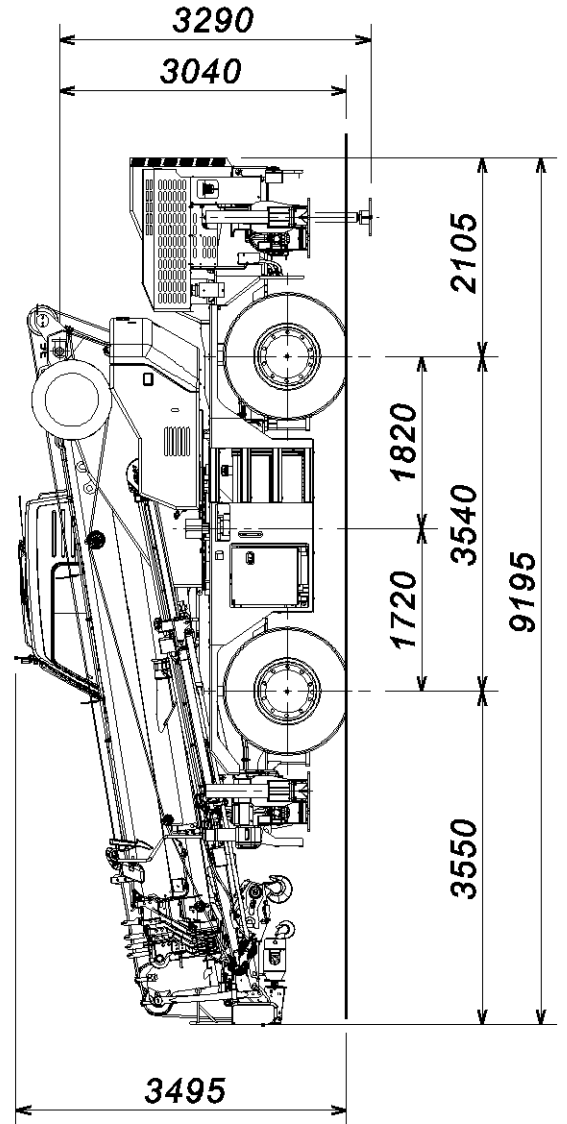
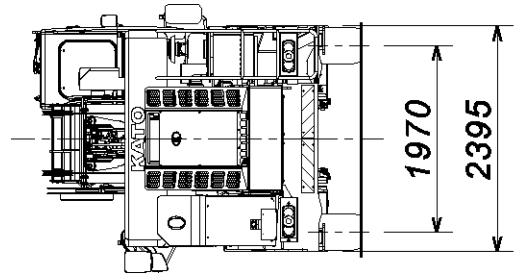
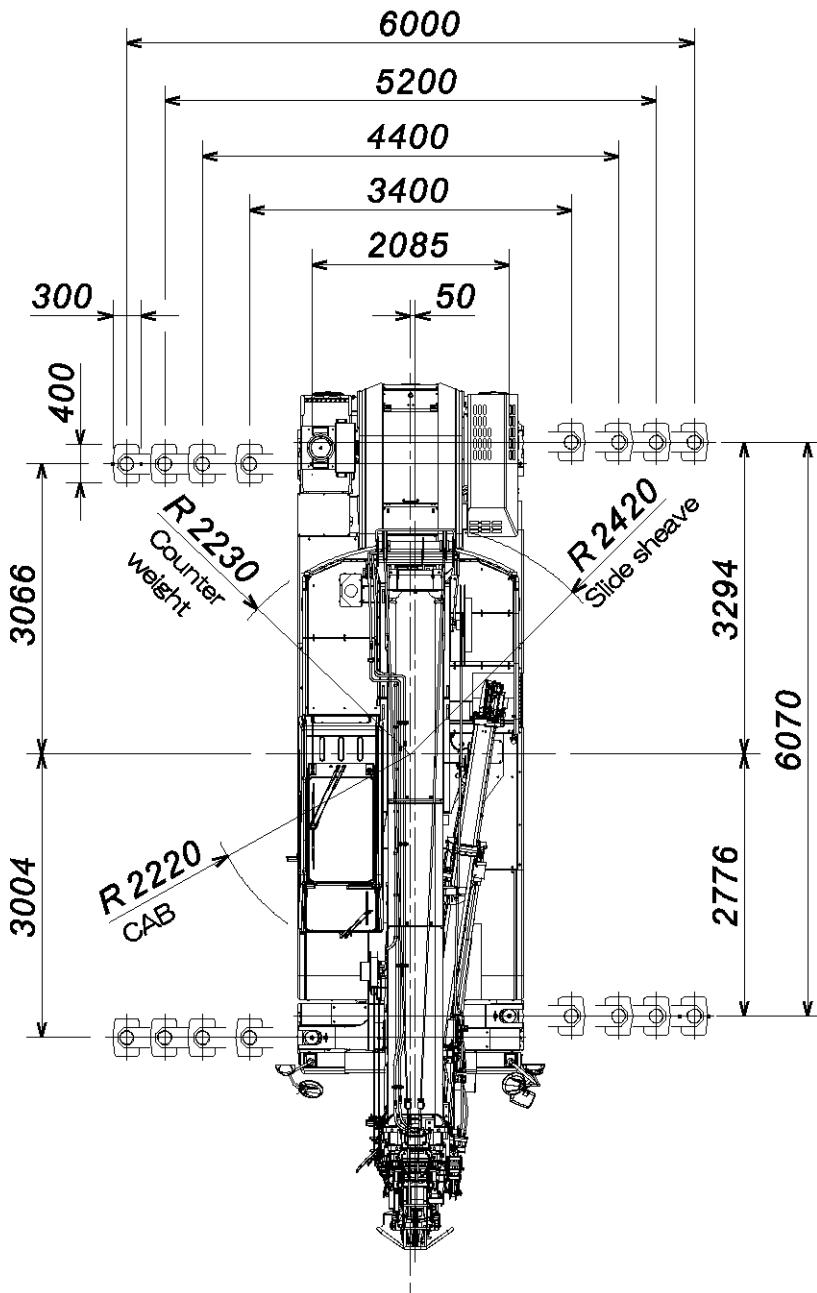

KATO CITY RANGE CRANE MODEL CR-250RV

WE RESERVE THE RIGHT TO MAKE SPECIFICATION
AND EQUIPMENT CHANGES WITHOUT NOTICE

CONCLUSION

This is the KATO CR-250RV specification, and should there be any further details you require information on, or any points you wish to have clarified, please do not hesitate to contact our Overseas Marketing Department at ; -

KATO WORKS CO., LTD.

9-37, Higashi-ohi 1-chome,
Shinagawa-ku, Tokyo, 140-0011 Japan

Phone : Head Office

Tokyo (03)3458-1111

Overseas Marketing Dept.

Tokyo (03)3458-1115

Fax. : Tokyo (03) 3458-1151

where our Overseas Marketing Dept. staff will be happy to assist you.